



# DESIGN NOTES

## High Power Synchronous Buck Converter Delivers Up to 50A

Design Note 156

Dale Eagar

### Introduction

The LT<sup>®</sup>1339 is the buck/boost controller that needs no steroids. As a full-featured synchronous switching controller, the LT1339 incorporates the features needed for system level solutions. The unfortunate lack of such features in most PWM controllers forces designers to grope for handfuls of jellybean components. The LT1339 has an innovative slope-compensation function that allows the circuit designer freedom in controlling both the slope and offset of the slope-compensation ramp. Additionally, the LT1339 has an average current limit loop that yields a constant output current limit, regardless of input and/or output voltage. The LT1339 has a RUN pin that is actually the input to a precision comparator, giving the designer freedom to select an undervoltage lockout point and hysteresis appropriate for the design. The SYNC and SS (soft start) pins allow simple solutions to system level design considerations. Like all Linear Technology controllers, the

For input voltages ranging from 12V to 48V and output voltages ranging from 1.3V to 36V, the LT1339 is a simple robust solution to your power conversion problems. The LT1339 is ideal for power levels ranging from tens of watts to tens of kilowatts. The LT1339 is straightforward and remarkably easy to use. This is one power controller that is not afraid of 20A, 50A or even 150A of load current.

LT1339 has anti-shoot-through circuitry that ensures the robustness that is demanded in real world applications for medium and high power conversion.

### Distributed Power

Figure 1 details the typical low voltage buck converter. This circuit has a  $V_{IN}$  range of 10V to 18V with configurable output current and voltage. This simple circuit delivers 250W of load power into a 5V load while maintaining efficiencies in the mid nineties.

LT, LTC and LT are registered trademarks of Linear Technology Corporation.

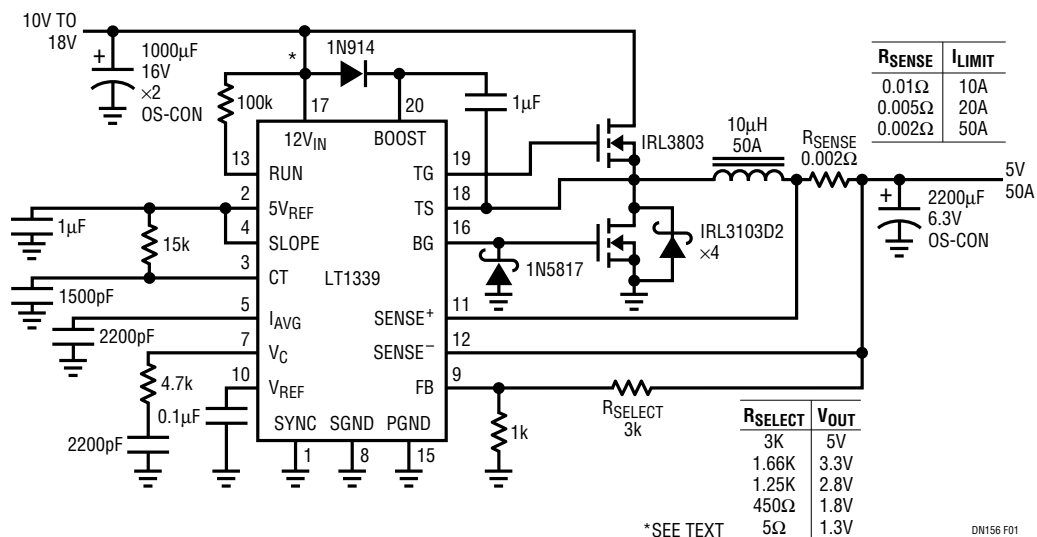

Figure 1. 10V<sub>IN</sub>-18V<sub>IN</sub> to 5V<sub>OUT</sub>, 50A Buck Converter

## Higher Input Voltages

The circuit shown in Figure 1 is limited to 20V because of the maximum rating (Abs Max) of the LT1339  $V_{IN}$  pin. The input voltage can be extended above 20V by inserting a 10V Zener diode in the circuit of Figure 1 where the asterisk (\*) is shown. This will extend the input voltage of Figure 1's circuit up to 30V (the Abs Max ratings of the MOSFETs).

## Blame it on the Physicists

As the input voltage approaches 30V, the bottom MOSFETs will begin to exhibit "phantom turn-on." This phenomenon is driven by the instantaneous voltage step on the drain, the ratio of  $C_{MILLER}$  to  $C_{INPUT}$ , and yields localized gate voltages above  $V_t$ , the threshold voltage of the bottom MOSFETs. To defeat the physicists in this arena, in Figure 2 we add 3V of negative offset to the bottom gate drive. The physicists,

however, having lost a battle, have not yet lost the war. From their dirty bag of tricks they pull the body diode effect of the bottom MOSFETs. In Figure 1, we use *FETKY*<sup>TM</sup> MOSFETs, FETs with internal Schottkys in parallel with the body diodes. Because *FETKY* MOSFETs are not available in the higher voltages, we must use external Schottkys. Because the inductance of the loop formed by the body diode and the external Schottky is correspondingly much higher, body-diode current is slow to move into the Schottkys. Our solution is to use smaller Schottkys and interdigitize them with the bottom MOSFETs to reduce inductance. Figure 2 details the victory over the physicists in the form of a 48V<sub>IN</sub>, 5V<sub>OUT</sub>, 50A synchronous buck converter. When this converter is configured for 24V output, it can deliver 960W of power from either a 36V or 48V input while maintaining 97% efficiency.

*FETKY* is a trademark of International Rectifier Corporation.

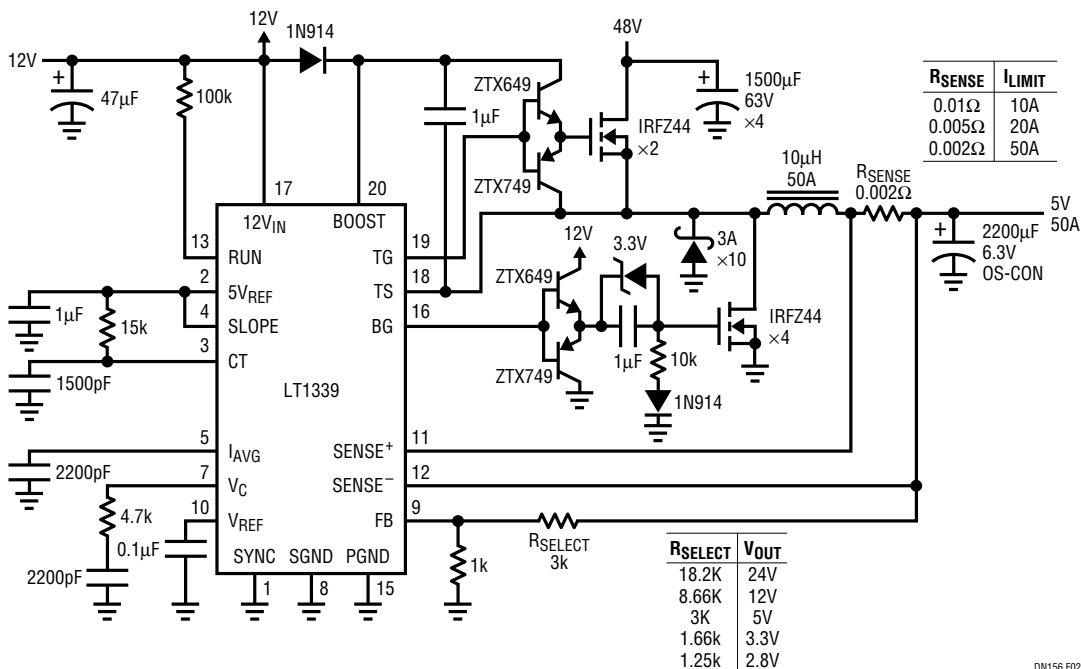

Figure 2. 48V<sub>IN</sub>, 5V<sub>OUT</sub> at 50A High Power Buck Converter

For literature on our Power Controllers, call **1-800-4-LINEAR**. For applications help, call (408) 432-1900, Ext. 2360

## Linear Technology Corporation

1630 McCarthy Blvd., Milpitas, CA 95035-7417 • (408) 432-1900  
 FAX: (408) 434-0507 • TELEX: 499-3977 • www.linear-tech.com

dn156f LT/TP 0697 185K • PRINTED IN THE USA



© LINEAR TECHNOLOGY CORPORATION 1997